

## SILICON IRON TUBULAR ANODES

Tubular silicon iron anodes, produced by Corrpro Companies Europe Limited, are designed for the effective protection of steel structures and pipelines from corrosion by the impressed current method. They are manufactured from high silicon cast iron alloy, one of the most important anode materials used by the corrosion engineer to protect steel in a variety of situations.

### Specification Composition Typical analysis: ASTM A518-86 Grade 3 and BS.1591

Element	Composition,
Silicon	14.20-14.75%
Manganese	1.5% max
Carbon	0.7-1.10%
Chromium	3.25-5.00%
Molybdenum	0.20% max
Copper	0.50% max

Other compositions available to specification

#### Technical Data

Tensile Strength (1/2" dia. Bar) psi	15,000
Compressive Strength	100,000
Brinell	320
Density gr/ml	7.0
Melting Point °F	2,300
Connection Resistance (Ohms)	Less than 0.004

### Suitable Installations

Silicon Iron Tubular anodes have been proved reliable in any of the following installations:-

- Open hole deep groundbeds
- Closed hole deep groundbeds
- Sea water or brackish water installations
- With or without conductive backfill or canisters

### Consumption of Anode Material

In tests and real life installations, up to 99.8% of the anode material has been consumed. Consumption figures of 88% and 93.5% are commonplace. A consumption rate of around 0.2kg Ampere year has been achieved on many occasions.



## SILICON IRON TUBULAR ANODES

### Standard Range of Tubular anodes

Below is a table showing the range of CCEL tubular anodes. Details on non standard sizes and weights of anode are available upon request. Dimensions and weights are shown are nominal ( $\pm 5\%$ )

CCEL Ref	Outside Dia.		Length		Inside Dia.		Min. Weight		Surface Area		Nominal Discharge (Amps)
	Inch	mm	Inch	mm	Inch	mm	lb	kg	sq ft	sq mm	
BTU-1	2.8	71	42	1067	1.8	45.7	31	14	2.4	0.2	1.5-2.0
BTU-2	2.3	58	84	2134	1.4	35.6	46	20.9	4.0	0.4	3.0-4.0
BTU-3	2.8	71	84	2134	1.8	45.7	63	28.6	4.9	0.5	3.5-5.0
BTU-4	3.8	96	84	2134	2.9	74.4	85	39.2	6.9	0.6	6.0-7.0
BTU-5	4.9	124	84	2134	3.9	99	110	49.9	8.7	0.8	6.0-8.5
BTU-6	4.9	124	84	2134	3.4	86.4	175	79.4	8.7	0.8	9.0-10.0

### Why Tubular?

- ❑ The surface area of a silicon iron anode is often the determining factor for anode selection. This can mean the volume of metal is far greater than that required to meet the design requirements. Tubular anodes achieve the required surface area with considerably less weight.
- ❑ The anodes are centrifugally cast which avoids many of the potential problems and defects associated with traditionally cast anodes. The sophisticated centrifugal casting technique ensures a homogenous casting of uniform thickness and excellent surface finish.
- ❑ Anodes can be supplied bare (for customer connection of the cable) or fitted with a cable tail using the CCEL developed high strength, low resistance central cable connection which is resin encapsulated. Central connection overcomes "the end effect" and ensures the anode will provide the required current throughout the design life.
- ❑ The tubular design helps reduce the electrolyte resistance and lower current density compared to solid anodes with an equivalent anode weight and current output.

### CCEL Tubular anode standard cable connector

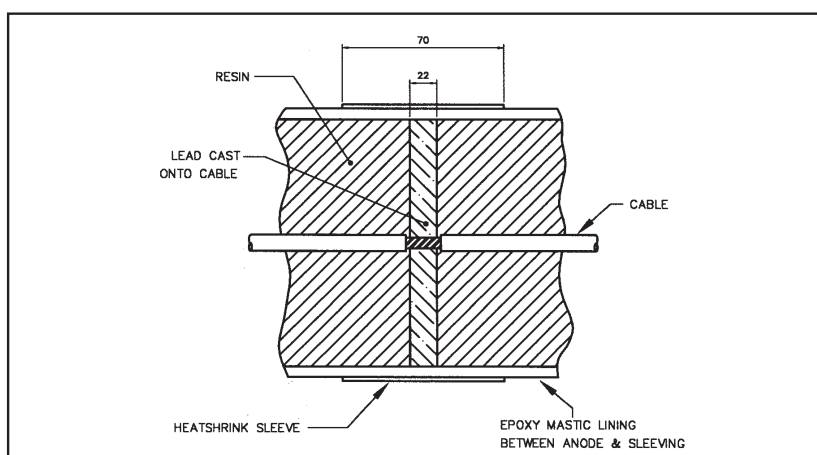

**Corrpro Companies Europe Limited**  
 Adam Street, Bowesfield Lane, Stockton on Tees, TS18 3HQ  
 Telephone: (01642) 614106 (8 lines) Telex: 587388  
 Fax: (01642) 614100 E-mail: ccel@corrpro.co.uk